



Commercial
Vehicles

The Caddy and Caddy Maxi





Overseas model shown.



Caddy® puts the fun back into work.

What is it about the Caddy that makes it Australia's most favourite compact van? Is it the brilliant drive characteristics that make it handle more like a car than a van? The array of safety equipment? The extraordinary cargo space in the rear? The versatility? Perhaps it's the style... the sleek new face that matches the new 'family' look? The cute rounded corners and happy shape that makes people smile whenever Caddy slips past in busy city traffic?

Whatever it is, there's absolutely no doubt business people all over the

nation love the Caddy. Evidence of this is everywhere, with the clever designs that adorn almost every Caddy on the road. And that's one of the most important features of the Caddy, how it is an essential marketing tool for businesses that wish to express their personality. New Caddy says that you take your business, and your customers, seriously. At the same time, it speaks volumes of how much you enjoy your work. And because there are more working days than weekend days, shouldn't we be having a little fun at work?



Overseas model shown.



You can see the family resemblance.

There are many more refinements to the latest Caddy than the stylish new face that matches the family DNA. But there's little doubt that the new Volkswagen family appearance captures considerable attention. The new headlights, bumper and grille, which are matched with a new bonnet and front guards, yield a more aggressive appearance that gives Caddy extra edge. Still cute, but cute with attitude.

Caddy also boasts new instrumentation, a new steering wheel, optional audio and navigation systems and new engine options under that sleek new bonnet. It's one amazing package.



Overseas model shown.



01 Electronic Brakeforce Distribution (EBD) prevents lock-up of the rear wheels when the vehicle weight is transferred to the front wheels under heavy braking.



02 The seat belt warning reminds the driver that their seat belt is not fastened.



03 The Electronic Stabilisation Programme (ESP), including hill holder, prevents the vehicle from swerving in critical driving conditions.



04 The Anti-lock Braking System (ABS) prevents wheels from locking up and improves manoeuvrability.



05 The Brake Assist system recognises the speed at which the brake pedal is pushed. Under reflex or emergency braking, the system senses the urgent need and applies full brake pressure more rapidly.



Built to drive.

Cargo out back. Car up front.

The consensus from Caddy owners is that the Caddy handles just like a quality passenger vehicle. And if you love driving (who doesn't?) then Caddy really does put the fun back into work. Zip up city streets. Whip down alleyways. Nip in and out of traffic with ease. Yes, Caddy is the ultimate urban delivery van because it doesn't feel like you're driving a van.

With new engines and new transmissions paired to a new electro-mechanical power steering system, driving a Caddy is guaranteed to change the way you feel about work. Then there's the assortment of car-like driving technology and instrumentation at hand that provides Caddy with a truly ergonomic environment. If you're the boss of your own small business and you're the one behind the wheel, then you owe it to yourself to be as comfortable as possible at work. If you happen to be running a fleet of Caddys, then you're effectively optimising the work output of your team by providing them with a vehicle that makes it easy to get the job done efficiently.

But performance and driving enjoyment is only part of the equation. Safety is also paramount, and in this respect, Volkswagen leaves no stone unturned. Meticulous German design and robust construction accompanies a long list of safety and security features built into every Caddy. The cargo in the back might be important, but to us, the cargo up front is infinitely more precious.

Passive safety features include driver and front passenger airbags with the option of side head and thorax airbags. Caddy also features ESP (Electronic Stability Program) and TCS (Traction Control System) as standard, which keep you safe

when the road conditions aren't. You also benefit from ABS (Anti-lock Braking System), EBA (Electronic Brake Assist) and EBD (Electronic Brake Distribution) – absolute essentials for ducking in and out of inner city streets and negotiating constantly changing traffic conditions.

Of course, while Caddy is the perfect urban van, that doesn't mean it only loves the city. Caddy is a joy to drive on the open road and handles beautifully on the freeway. And if you're likely to encounter more challenging surfaces with varying grip (think country roads or muddy worksites here), there's always the option of Caddy Maxi with 4MOTION all-wheel drive.

If your business is more about inner city driving, why not make it even easier with Volkswagen's Direct Shift Gearbox (DSG). Unique in the commercial vehicle sector, the DSG system is not just one automatic clutch... it's two, working in tandem to deliver the smoothest, fastest, most efficient auto transmission anywhere.

While one clutch is engaged and powering your Caddy along, the other is ready to accept the next gear. This twin clutch technology means you can change gear much faster than with a standard automatic gearbox – actually in less than four hundredths of a second. Think about the stop-start nature of working in the city and you'll realise just how valuable DSG will be in your Caddy.





Caddy Van.



When Caddy Van first entered the market in Australia, it took a lot of people by surprise. The combination of an easy-to-drive vehicle that was economical, manoeuvrable in tight urban environments, versatile and could take considerable cargo became irresistible for many business owners. The good news is that nothing in this regard has changed. While there have been key changes to the front end of the vehicle and to the list of

specifications and equipment, the cargo space remains at a class leading 3.2m³ with an incredible payload of up to 741kg.

If you really don't need a one-tonner and want all the driving and efficiency benefits that many one-tonners struggle to deliver, then Caddy will fit the bill.

Greengrocers to auto mechanics. Florists to plumbers. We know the range of businesses

that rely on Caddy, so we made sure that the back end of the vehicle can be tailored to suit your needs with all sorts of factory options. Add a second sliding door, put in a cargo barrier, install some purpose built flooring, or have your Caddy with tailgate and heated window. Easy. And if you already own the previous model with a specialised fitout, the great news is that you can upgrade to the new model and bring your existing fitout with you.



Caddy Maxi Van.

If Caddy isn't quite enough van for you and you need to fit more in, Caddy Maxi Van is here to the rescue. Think of Caddy Maxi Van as the long wheelbase Caddy. Half a metre longer in fact.

You might be surprised by just how much extra space this yields. Caddy Maxi Van virtually steps out of the compact van segment to give every other one-tonner on the road a run for its money. The load space in the rear of

a Caddy Maxi is 2.25m long, with a load volume of 4.2m³ and a payload of 800kg (DSG) or 850kg (manual). For a compact van, that's big – easily the biggest in its class. With dual sliding doors as standard on Caddy Maxi Van and dual wing doors at the rear, all this cargo space is incredibly easy to access. For serious tradesmen with bigger equipment or mixed businesses with larger product, Caddy Maxi Van makes tremendous sense. It gets in and out of those tight

spaces just like Caddy Van does, and is just as enjoyable to drive.

If you think an extra cubic metre must have impacted on the area up front, think again. There have been no compromises on the driver and passenger space. Comfort, safety and ergonomics are first class. And just like Caddy Van, if you're upgrading from a previous model of the Caddy Maxi Van, your specialised fitout can be swapped over easily.



4MOTION

While more cargo space and payload is great, if your Caddy goes with you to, say, a muddy worksite, you can't afford to slip and slide with heavy gear on board.

Enter 4MOTION – Volkswagen's clever all-wheel drive system that provides your Caddy with extra grip in standard off-road situations.

The tractive force of the Caddy 4MOTION is distributed by Volkswagen's ingeniously designed, electronically regulated 4th generation Haldex coupling system. As soon as the system detects any differences in the speeds of rotation between the front and rear axles, two annular piston pumps are activated which build up pressure in the multi-plate Haldex system – effectively “coupling” the two axles to each other. The coupling provides an infinitely variable torque transfer between the front and rear axles, depending on the degree of slip in the rear or the front. Of course, you won't be aware of the lightning quick adjustments being made by the system beneath you. All you will feel is sure-footed handling.

Amazing new engines.

New engines sit beneath the stylish new bonnet of both Caddy Van and Caddy Maxi Van delivering new levels of performance, sharper fuel efficiencies and kinder environmental outcomes.

The new Volkswagen TSI160 and TSI175 continue to break new ground with TSI technology. These engines, coupled with five-speed manual transmissions deliver an economical 63kW and 160Nm of torque, or an amazing 77kW of power

and a healthy 175Nm of torque. At the bowser, to say it is cost effective is an understatement, achieving fuel consumption figures from 6.8L to 7.0L/100km, according to vehicle specification. In combined-cycle testing, the engine emits between just 154 and 158g/km of CO₂.

The next engine up is the new TDI250 (common-rail) turbo diesel available with either a standard five-speed

manual or a seven-speed DSG transmission. This engine develops 250Nm of torque and achieves staggering fuel efficiencies of 5.7 to 5.8L/100km, emitting from just 149 to 152g/km of CO₂. Since it develops more torque, the TDI320 is offered with a six-speed DSG as standard. The engine itself generates 320Nm of torque and still achieves incredible fuel efficiencies of just 6.3L/100km while emitting lower CO₂ emissions than ever before.

Engine specifications.

Engine	TSI160	TSI175	TDI250	TDI320
Type	4 Cylinder, SOHC, 8 Valve	4 Cylinder, SOHC, 8 Valve	4 Cylinder, DOHC, 16 Valve	4 Cylinder, DOHC, 16 Valve
Installation	Transverse installation	Transverse installation	Transverse installation	Transverse installation
Construction materials	All alloy	All alloy	Alloy head with cast iron block	Alloy head with cast iron block
Capacity, litres/cc	1.2 / 1,197	1.2 / 1,197	1.6 / 1,598	2.0 / 1,968
Bore x Stroke / Compression ratio	71 x 75.6 / 10:1	71 x 75.6 / 10:1	79.5 x 80.5 / 16.5:1	95.5 x 81 / 16.0:1
Maximum power, kW @ rpm	63 @ 4,800	77 @ 5,000	75 @ 4,400	103 @ 4,200
Maximum torque, Nm @ rpm	160 @ 1,500 – 3,500	175 @ 1,550 – 4,100	250 / 1,500 – 2,500	320 / 1,500 – 2,500
Fuel system	Direct Injection	Direct Injection	Common Rail Direct Injection	Common Rail Direct Injection
Induction type	Single-turbocharger	Single-turbocharger	Single-turbocharger	Single-turbocharger
Emissions standard	Euro 5*	Euro 5*	Euro 5* with Diesel Particle Filter (DPF)	Euro 5* with Diesel Particle Filter (DPF)
Fuel type	Petrol	Petrol	Diesel	Diesel
Fuel tank capacity	60 Litres	60 Litres	60 Litres	60 Litres
Transmission				
Transmission – manual	5 Speed Manual	5 Speed Manual	5 Speed Manual	n/a
Transmission – automatic	n/a	n/a	7 Speed DSG	6 Speed DSG
Driven wheels	Front wheel drive	Front wheel drive	Front wheel drive	Front wheel drive (4MOTION)
Wheels and Tyres				
Wheels	Steel 6.J x 15	Steel 6.J x 15	Steel 6.J x 15	Steel 6 J x 16
Tyres	205 / 55 R15 91T	205 / 55 R15 91T	205 / 55 R15 91T	205 / 55 R16 94H

* Emission level according to European Regulation (EC) No. 715/2007 and Regulation (EC) No. 692/2008. The information and the specifications contained within this document were correct at the time of issue. Due to our continuous process of improvement our products are continually updated and changes may be made to the specifications from time to time. Not all vehicles or options may be available. Check at time of ordering.

Dimensions and weights.

Dimensions	Caddy Van	Caddy Maxi Van
Length, mm	4,406	4,876
Width, mm	1,794	1,794
Height std	1,823	1,836
Wheelbase, mm	2,681	3,006
Interior Dimensions (Wheelbase – Roof height)		
Load volume, m ³	3.2	4.2
Maximum length, mm	1,781	2,250
Maximum width, mm	1,552	1,552
Maximum width at wheel arches, mm	1,172	1,172
Maximum height, mm	1,244	1,262
Cargo entry		
Rear tailgate width, mm	1,185	1,185
Rear tailgate height, mm	1,129	1,132
Lateral sliding doors width, mm	701	701
Lateral sliding doors height, mm	1,100	1,100
Tie down points	6	8
Warranty		
Vehicle	3 Years, Unlimited km	3 Years, Unlimited km
Paint / Corrosion	3 Years / 12 Years	3 Years / 12 Years
Road side assistance	3 Years, Unlimited km	3 Years, Unlimited km

Weights	Caddy Van		Caddy Maxi Van		
	TSI160	TDI250	TSI175	TDI250	TDI320
GVM, kg	2,089	2,175(Man)	2,233	2,310(Man)	2,349
Towing capacity, braked / unbraked	1,300kg / 670kg	1,500kg / 710kg	1,300kg / 670kg	1,500kg / 710kg	1,500kg / 710kg
Towing downball load	75kg	75kg	75kg	75kg	75kg
Kerb weight (includes driver)	1,309	1,395 (Man) 1,445 (DSG)	1,383	1,460 (Man) 1,510 (DSG)	1,549 1,649 (4MOTION)
Payload Manual	780	780	850	850	800
Payload DSG	-	730	-	800	700 (4MOTION)

Caddy Van.

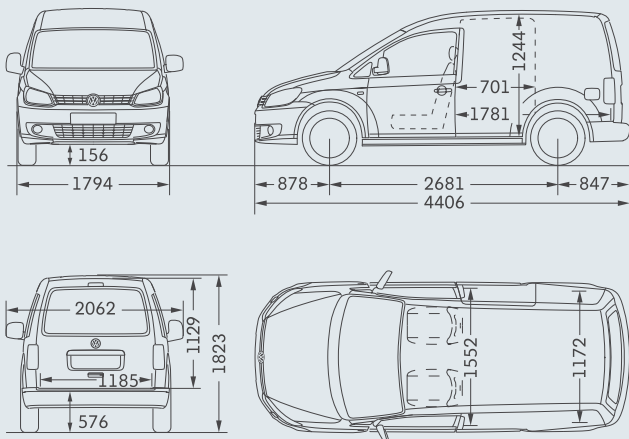

Caddy Maxi Van.

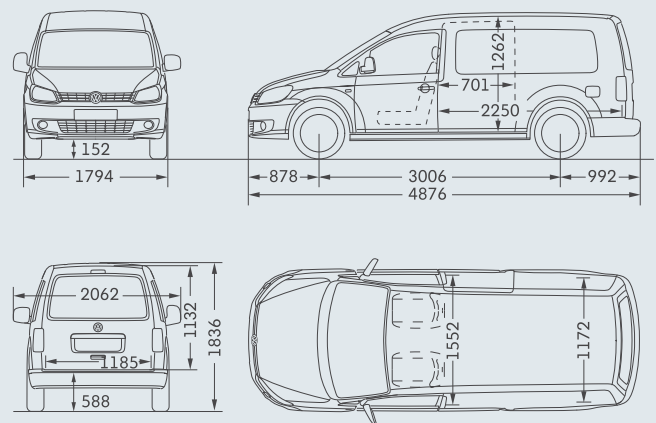

Standard Specifications.

Safety and Security	
Driver and front passenger airbag	
Daytime Running Lights	
Electronic Stability Program (ESP)	
Remote central locking with 2 remote keys	
Front height adjustable 3-point seatbelts with pre-tensioners	
Electronic engine immobiliser	
Driver Assistance Systems	
Hill Hold Assist	
Exterior	
Rear fog lamp	
Electrically adjustable door mirrors with heating function	
Left hand side sliding door	
Rear wing doors with heated windows	
Interior	
RCD210 Radio CD Player with MP3 Single Din with Aux-In	
"Climatic" Air Conditioning	
3 Spoke steering wheel	
Driver and front passenger seat with height adjustment, under seat storage and grab handles (2)	
Overhead storage	
Cloth seats with "Place" fabric and Anthracite trim	
Convenience	
Front electric windows with roll-back function	
Driver and passenger with one-touch up/down	
Heated window on rear tailgate or barn doors	
Instrumentation	
Speedometer and tachometer, electronic odometer and trip meter, digital clock, fuel & coolant indicators, low fuel warning light, outside temperature and fuel gauge.	
Mechanical	
Electromechanical steering	

Suspension and brakes specifications.

Suspension & Steering	Caddy Van		Caddy Maxi Van	
	TSI160	TSI175	TDI250	TDI320
Front axle	Independent McPherson struts, sub frame with coil springs and gas filled dampers			
Rear axle	Rigid rear axle with Leaf Springs			
Steering	Speed sensitive electro-mechanical power steering			
Turning Circle	SWB: 11.1m / LWB: 12.2m			
Brakes				
Front Disc brakes (Vented)	280 X 22mm	288 x 25mm	288 x 25mm	312 X 25mm
Rear Disc brakes (Solid)	253 x 10mm	253 x 10mm	253 x 10mm	272 x 10mm
Brake systems	ESP, ABS, ASR, MSR, EDL and Hill Holder	ESP, ABS, ASR, MSR, EDL and Hill Holder	ESP, ABS, ASR, MSR, EDL and Hill Holder	ESP, ABS, ASR, MSR, EDL and Hill Holder

The information and the specifications contained within this document were correct at the time of issue. Due to our continuous process of improvement our products are continually updated and changes may be made to the specifications from time to time. Not all vehicles or options may be available. Check at time of ordering.

Factory options.

	Caddy Van	Caddy Maxi Van
Paint Options		
Metallic paint	O	O
Pearl effect paint	O	O
Safety and Security		
Driver and front passenger head and thorax airbag	O	O
Alarm system with back-up horn	O	O
Park distance control – rear	O	O
Light and Sight package – includes dusk sensing headlights with “coming home” function, rain sensing wipers and auto dimming rear view-mirror	O	O
Suspension Upgrade (Suggested for applications where constant payload over 250kg is fitted)	O	O
Exterior		
Body coloured bumpers, mirror housing and door handles	O	O
Fixed window in right hand sliding door	–	O
Fixed window in left hand sliding door	–	O
Front fog lamps with cornering function	O	O
Tailgate heated windows	O	O
Right hand side sliding door	O	S
Roof rails (black)	O	O
Window package (4 x fixed windows)	O	O
16” x 6J alloy wheels “Siracusa” with 205/55 R16 94H tyres (not for TSI160)	O	O
Interior		
Rubber floor for cargo area	O	O
Carpet floor covering in cab	O	O
“Climatronic” dual zone air-conditioning	O	O
Leather steering wheel with multifunction controls	O	O
Multifunction display – shows trip kms, trip time, average fuel consumption, actual fuel consumption, range, digital speed reading, oil temperature and speed warning	O	O
RCD310 Radio CD Player with MP3 double DIN with Aux-In	O	O
RNS510 Satellite Navigation, 30GB HD, 4 speakers and multifunction display with Aux-In	O	O
Cover for tray on dashboard	O	O
Convenience		
Cruise control	O	S
Cruise control with multifunction display	O	O





S = Standard – = Not Available O = Optional

Fuel consumption and performance.

	Caddy Van		Caddy Maxi Van	
	Caddy Van TSI160	Caddy Van TSI175	Caddy Maxi Van TDI250	Caddy Maxi Van TDI320
	Comb / Urban / Ex Urban • CO ₂	Comb / Urban / Ex Urban • CO ₂	Comb / Urban / Ex Urban • CO ₂	Comb / Urban / Ex Urban • CO ₂
Fuel Consumption – ADR81/02				
Caddy Manual, Litre/100km • CO ₂	6.9 / 8.2 / 6.1 160g/km	–	5.7 / 6.6 / 5.2 149g/km	–
Caddy DSG, Litre/100km • CO ₂	–	–	5.7 / 6.5 / 5.2 149g/km	–
Caddy Maxi Manual, Litre/100km • CO ₂	–	7.0 / 8.3 / 6.2 163g/km	5.8 / 6.7 / 5.3 152g/km	–
Caddy Maxi DSG, Litre/100km • CO ₂	–	–	5.8 / 6.6 / 5.3 152g/km	6.3 / 7.6 / 5.5 166g/km
Caddy Maxi 4MOTION, DSG, Litre/100km • CO ₂	–	–	–	6.7 / 8.3 / 5.9 177g/km

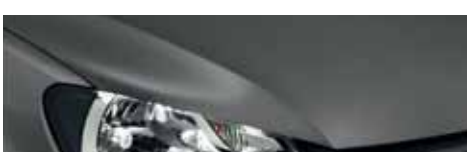
Paint colours.

The bodywork is first galvanised to give your Volkswagen vehicle optimum protection against mechanical and chemical influences. Only then is the paint applied in several layers and left to harden. The result is a scratch-proof, hard finish for the top coat.

	Candy White solid paint B4B4		Luminous Orange solid paint E3E3
	Beluga Blue solid paint D0D0		Salsa Red solid paint 4Y4Y
	Sunny Yellow solid paint M9M9		Primavera Green solid paint E0E0
	Pure Grey solid paint J2J2		Black Berry* metallic paint COCO
	Natural Grey* metallic paint M4M4		Lava Red* metallic paint FOFO
	Toffee Brown* metallic paint 4Q4Q		Night Blue* metallic paint Z2Z2
	Reflex Silver* metallic paint 8E8E		Ravenna Blue* metallic paint 5Z5Z
	Venetian Green* pearl effect paint E5E5		Deep Black* pearl effect paint 2T2T

Trim.

	Place Classic Grey/ Anthracite cloth upholstery RF
--	---

High-quality, robust materials and skilled workmanship are essential in the manufacture of hard-wearing seat upholstery. The colours and patterns for the upholstery are painstakingly matched to the interior trim and paint finishes.

*Available at extra charge. The illustrations on these pages can only be regarded as a general guide as the printing process cannot render the colours with absolute accuracy. Please contact your local Volkswagen dealer for details of the standard equipment and optional extras available.

Accessories.



Load Sill Protection Strip.

This brushed chrome strip is shaped to fit the curvature of the rear bumper of the Caddy and shields against scratches during standard loading and unloading.



Rear cargo net. If you occasionally carry small, light loads, this handy net keeps items from sliding around in the load compartment. Securing hooks and lashing eyes are available to fasten the net.



Rubber floor mats. These rugged mats with Caddy motif are available for both the passenger and drivers side and do an excellent job of protecting the floor from wear and tear and dirty work boots.



Rear window protection. If you're carrying heavy, bulky goods, you might consider installing this robust steel grille for the windows of the rear wing door to protect against knocks and bumps on the road. They're a great protection against theft too.



Rear boot tub. This tough plastic tub with Caddy motif fits neatly into the rear load space of the Caddy. Perfect for catching the grime and dirt, and can be taken out quickly to hose off.



Bluetooth Phone Kit. Negotiating around busy roads and taking calls on the fly is now much easier thanks to this handy Bluetooth phone kit. Pairs quickly with all major phones and installs neatly on the dash.



MEDIA-IN interface. Allows you to connect external audio sources including USB, USB mini, 3.5mm jack and iPod. Plays your favourite tracks through the vehicles audio system.



Roof bars and ladder rack. This roof rack system offers you a solution to maximise the roof for extra load space. With a range of roof attachments your favourite sporting equipment can be securely mounted.

Owning a Volkswagen.

Volkswagen New Vehicle Warranty

Volkswagen Caddy and Caddy Maxi are covered by a 3-year/unlimited kilometre manufacturer's warranty, which includes Volkswagen Assist (24hr roadside assistance). Caddy is also covered by a 3-year paintwork and 12-year anti-corrosion perforation warranty.

Volkswagen Assist

24 hour roadside assistance

As a valued customer, you can be assured that, wherever you travel within Australia, you will have access to roadside assistance, 24 hours a day, 365 days a year. This is complimentary for the duration of the vehicle's original Volkswagen warranty period. You will receive help in the event of a breakdown

or accident and, if required, your vehicle will be mobilised or transported to an Authorised Volkswagen Repair Centre.

Volkswagen Extended Warranty

Why not continue the confidence of a Volkswagen Warranty by purchasing a Volkswagen Extended Warranty? For further details on this option, please contact your local Volkswagen Dealer.

Volkswagen Service

Your Authorised Volkswagen Service Centre is part of Volkswagen's global Quality Management System, ensuring all dealers are certified to ISO 9001:2000 – an internationally recognised Quality Standard. Authorised Volkswagen Service Centres have factory trained technicians equipped with the very latest diagnostic

equipment, specialist tooling and Volkswagen Genuine Parts. An Authorised Volkswagen Service Centre undertakes work in accordance with factory specified guidelines and maintenance schedules.

Volkswagen Genuine Parts®

Volkswagen Genuine Parts® are designed for your vehicle and approved by Volkswagen, with particular regard to safety. The workmanship, dimensional accuracy and materials used in these parts comply with factory specifications. To ensure safety and reliability, Volkswagen recommends the use of Volkswagen Genuine Parts®. Volkswagen Authorised Dealers offer a 2-year warranty on Genuine Parts from the date of purchase.

Environment.

At Volkswagen, we don't see the word 'Environment' as a barrier. We believe that sound environmental sustainability offers the opportunity to develop long-term innovations, including new approaches, efficient technologies and ground-breaking products. An internal Environment Committee was established in order to manage our business activities from an environmental point of view and to find solutions to reduce our environmental impact.

As a first and important step, Volkswagen Group Australia have developed a Carbon Management Strategy helping us to identify and manage our carbon emissions from our business activities.

This has led to a Carbon Management Program throughout the organisation, empowered to recommend changes that mean real emissions reductions. From reduced electricity consumption to optimised business flights, we're making

changes to reduce our carbon footprint. On a local level, we have also undertaken a number of initiatives to reduce the environmental impact of our business processes, from office recycling to using waterless urinals in bathrooms. Energy usage is being reduced through lights controlled by motion sensors in toilets, kitchens and meeting rooms.

But there's no question that the area in which we can contribute most to environmental sustainability is with our vehicles. Our TSI twin or single-charged engines combine innovative and world leading direct injection petrol technology with turbocharging and are extremely fuel efficient with reduced CO₂ emissions. Our TDI diesel engines consume less fuel and emit less exhaust fumes offering high torque and performance, while our diesel particulate filters extract soot from the exhaust fumes. Numerous engines already fulfill the very stringent Euro 5 norm.

Our dual-clutch DSG gearbox provides the comfort of conventional automatic transmission and the dynamic drive of a manual transmission. It has significantly lower fuel consumption in comparison with a conventional automatic transmission with torque conversion. The newest member of our DSG family is the 7 gear DSG transmission for front transverse mounting, and is the first dual-clutch gearbox with a 'dry' double clutch, achieving exciting new fuel consumption efficiencies.

General Information.

Volkswagen is distributed by Volkswagen Group Australia Pty Ltd, The Lakes Business Park, 6 Lord St, Botany, NSW 2019. ABN 14 093 117 876. Specifications are as planned at December 2010 for model year 2010/2011 and are subject to change without notice or obligation. Cars and accessories are shown for illustrative purposes only and may not depict Australian specifications. Fuel consumption figures according to Australian Design Rules (ADR) 81/02. All Volkswagen approved parts and accessories are warranted for 2 years/unlimited kilometres. All warranties implied by legislation or otherwise are excluded to the maximum extent permitted by law. The liability of Volkswagen shall, subject to the law, be limited at Volkswagen's discretion: 1. In the case of the goods, the repair or the cost of repair, or the replacement or the cost of replacement; and 2. In the case of services, the re-supply of the services or the cost of re-supply of the services. All information in this brochure is correct at time of publication, however variations may occur from time to time and Volkswagen, in so far as it is permitted by law to do so, shall not be liable in any way as a result of any reliance by any person on anything contained in this brochure. The colours shown in the brochure are indicative only and may vary from actual items owing to the printing process. Authorised Volkswagen dealers will provide up-to-date information on model application, design feature, prices and availability on request.

Volkswagen Insurance & Volkswagen Extended Warranty are provided by Allianz Australia Insurance Limited (Allianz), AFS Licence No. 234708, ABN 15 000 122 580. In arranging this insurance, Volkswagen Financial Services Australia Limited, ABN 20 097 071 460 & Volkswagen Group Australia Pty Ltd, ABN 14 093 117 896 and the authorised dealers act as agents of Allianz and not as your agent. Volkswagen Finance is a trading name of Volkswagen Financial Services Australia Limited. Locked Bag 5009, Alexandria NSW 2015. Tel: 02 9695 6311.

The product name Caddy® is a registered trademark of Caddie S.A. and is used by Volkswagen Commercial Vehicles courtesy of Caddie S.A.

The Caddy and Caddy Maxi

VGACAD01 - Printed in Australia

Subject to change without notice

Issue: December 2010

Internet: www.volkswagen-commercial.com.au